

Guide to Installation, Maintenance & Repair

Section 1

Site Survey	3
Asses the aperture for suitability?	4
Measuring the aperture	5
Calculating the manufacturing sizes	6
Performance and Special Requirements	7
Structural loading requirements?	7
Installation techniques	7
Removing existing products	8
Installation – Aluminum windows and doors	9
Installation - Fixing	11
Installation - Glazing	12
Installation - Sealing	13
Installation - Commissioning	19

Section 2

CLEANING MAINTENANCE & REPAIR	
--	--

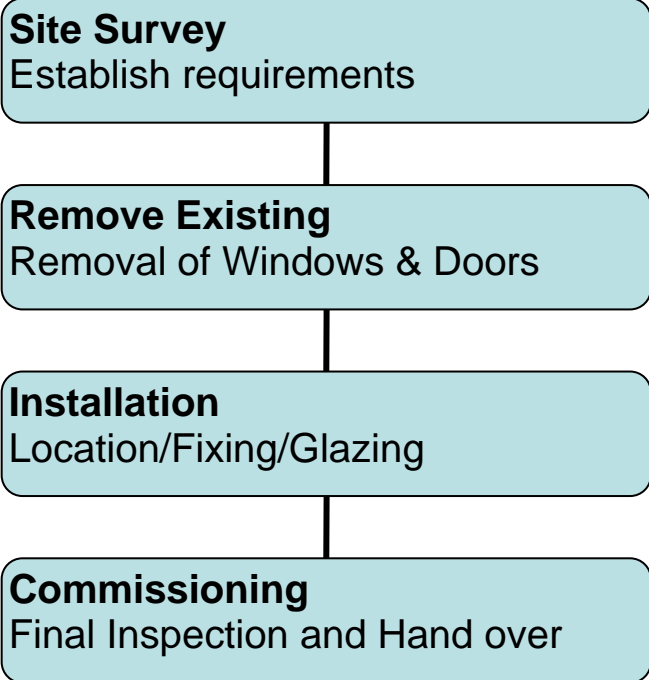

Site Survey

Good surveying is the basis of ensuring a quality installation. Surveyors should be fully trained in window and doorset installation techniques, and in the manufacturer's recommendations for the particular system being used.

- **Establish the Customers requirements?**
- **Asses the aperture for suitability?**
- **Measuring the aperture**
- **Calculating the manufacturing sizes**
- **Performance and Special Requirements**
- **Structural loading requirements?**
- **Installation techniques**

Establish the Customers requirements?

The surveyor should confirm with the purchaser whether the window or door is to be inward or outward opening and the handing and any special specification requirements. The surveyor is responsible to advise of hardware options and establish the purchasers requirements. In order to demonstrate compliance with Building Regulations (see Note 3), it is advisable to record the style of the window or doorset being replaced along with the size of any opening lights and the positions of any mullions and transoms. Ideally, this would be with the use of photographs and witnessed by the purchaser and countersigned.

The surveyor should inform the purchaser of any enhancements that could be made with respect to any apparent security issues. On outward opening doors, it is strongly recommended that a restriction device, e.g. a door stop positioned as close to the opening stile as possible, is fitted to help avoid damage caused by sudden wind gusts. The protrusion of outward opening windows into the path of pedestrians should be taken into account.

Asses the aperture for suitability?

The surveyor should check for any apparent defects and deficiencies around the structural opening. If any defects are found, then the purchaser should be notified, and agreement reached as to who is responsible for rectifying these defects prior to the new windows or doorsets being installed. For large replacement contracts, it can be advisable to remove one window or doorset to check the condition of the reveals and existing DPM, in so far as this is possible.

Additional Services? The presence of any electrical or specialist items such as television aerials and telephone wires in the aperture should be noted. Wherever possible such services should be routed around, and not through, the outer frame of the window or doorset. When this is not possible, a solution should be agreed with the purchaser which does not compromise the performance of the product.

The presence of any curtain tracks in the aperture should be noted. This is particularly important for inward opening or pivoting windows and net curtains. These could either cause problems during installation, or interfere with the function of the window or doorset after installation. Action to prevent any problems should be agreed with the purchaser prior to the installation.

Brickwork Removal? Where bricks are to be removed to install products, the method of any cavity closing should be specified. The method of making good should be agreed with the purchaser. It is advisable to consult local authority building control to ensure that any local interpretations, for instance with respect to cavity closing, are taken into account.

Measuring the aperture

Generally three measurements of width and height should be taken and the squareness of the aperture determined by, for example, taking diagonal measurements (see Figure 1). The smallest measurement of width and of height is used to determine manufacturing sizes.

Sub Sill Required?

The need for any sub-sill should be determined. The size of the sub-sill should be such that there is an overhang of at least 25 mm from the face of the building. The surveyor should determine how the sub-sill is to be fitted, taking into account features such as horns, and how any making good is to be carried out.

Checked Reveals?

The difference between internal and external reveal sizes should be determined and checks made to ensure that the operation of any opening light will not be impeded by plaster, render or tiles, etc. A window or doorset with a check reveal it is a good idea to remove an internal architrave from the window or doorset, to be see exactly how deep the reverse brick detail really is and to identify how much of the outer frame can be put behind in the width. A hole should be drilled through the head of the existing box frame to ascertain the maximum height the window or doorset can be put behind the brick. Quite often this differs greatly from the width. Once the amount of rebate is determined, the window/door height and width should be calculated, taking into account the deductions from Table 1 (see 5.15). If the rebate is sufficient, a 12 mm minimum overlap per side should be allowed. A deeper outer frame might be needed to allow opening out lights to adequately clear the masonry.

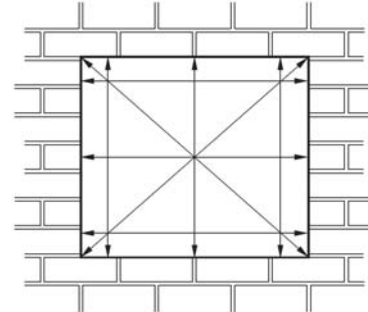

Calculating the manufacturing sizes

With some framing materials, significant expansion and contraction is to be expected due to temperature fluctuations, and this should be taken into consideration.

Allowances should also be made with regard to the window or doorset and building aperture tolerances. When calculating height deductions, due allowance should be also made for the thickness of any silicone or mortar bed at the sub-sill.

Material	Recommended deduction for width or height of structural opening			
	Up to 1.5 m	From 1.5 m to 3.0 m	From 3.0 m to 4.5 m ^{A)}	Over 4.5 m ^{A)}
GRP	5	10	15	15
PVC-U – white	10	10	15	20
PVC-U – non-white	15	15	22	28
Timber	10	10	10	15
Steel	8	10	12	15
Aluminium	10	10	15	20

NOTE 1 These deductions are from the total width or height, and are not “per side”.

NOTE 2 The gap required for effective polyurethane foam fixing at the head is 10 mm to 15 mm.

NOTE 3 When fitting aluminium or steel frames into existing timber sub-frames, deduct 4 mm.

^{A)} Intermediate expansion joints might be needed when the width or height exceeds 3 m.

Surveying for New Build

The manufacturing sizes and details of installation in new build are normally decided by the house designer in conjunction with the window and doorset supplier in accordance with current Building Regulations. The surveyor should ensure that the details agreed are suitable for the products to be used and are clearly defined.

NOTE The use of proprietary cavity closers/sub-frame systems can enable accurate construction of the opening and simple installation of the window and doorsets. Given the abuse that doors are often subjected to, caution should be exercised in adopting this method for the installation of doorsets. If in doubt, advice should be sought from the system supplier/manufacturer. It should be brought to the house builder's attention that factory-finished windows and doorsets need to be programmed for installation as late as possible in the building process to minimize the risk of damage.

Performance and Special Requirements

Performance and special requirements should always be considered, such as.

Weather-tightness	The surveyor should determine the design wind load for the application, and then determine whether the windows and doorsets are suitable for that exposure. BS 6375-1 gives guidance on selection and specification of windows and doorsets. Where any doubts exist, the manufacturer should be consulted.
Drainage	The surveyor should specify or confirm any method of drainage of frame and/or glazing to be used.
Thresholds	Consideration should be given to the type of threshold and any protection for it that will be required.
Letterplates Hardware	The size and location of any letterplate should be confirmed with the purchaser; Any requirements for additional hardware such as trickle vents, cat flaps, spy holes, etc., should be clearly specified;
Side Panels	on doorsets with side panels, it might be necessary to take mullion bounce into account and stiffen the mullion to limit this. Any such stiffening should be clearly specified.
Georgian Bars	The surveyor should specify or confirm the position, style and orientation of any glass pattern or decoration, including leading or Georgian Bar inserts, and the need for any alignment.
Planning Permission	Attention is drawn to the legal requirement to identify the need for any planning permission, e.g. for listed buildings or in conservation areas.
Risk Assessment	A risk assessment should be carried out for the suitability of the window or doorset design. The responsibility for this lies with the designer of the window or doorset, and it should be carried out by a competent person (commonly the surveyor). Suitable written records should be retained.
Cleaning Requirements	Information on the safety of windows (including door-height windows) in use and during cleaning is given in BS 8213-1. In the case of domestic replacement windows and doorsets, the designer is the person or organization taking the order from the purchaser.

Structural loading requirements?

When a load-bearing situation is suspected or confirmed then it is essential that the system supplier's recommendations are followed.

Bow Windows?	Where bow, oriel or dormer windows have applied loads, special structural calculations may be necessary. Where any doubts exist, the structure should be assumed to be load-bearing and reference made to the system supplier's instructions.
Coupled Windows?	Where windows and/or doorsets are to be coupled, the surveyor should determine the method to be used, taking into account wind and dead loads, visual appearance and position of the coupling.
Window/Door Lintel?	The surveyor should take reasonable steps to check that there is a lintel or other means of supporting the structure above the window or doorset. Where no such support exists and the load is carried on the existing window or doorset, then alternative means of providing this support should be provided.

Installation techniques

Wherever possible the survey should identify any necessary variations to standard installation techniques such as lug fixing or direct fixing.

Removing existing products

The installation team should ensure that all relevant documentation, e.g. drawings, survey sheets, special instructions, etc., is available and understood, and that the relevant products and equipment are available. Prior to the commencement of work the sizes, type, and condition of all windows and doorsets should be checked both against the survey sizes and types and against the actual aperture sizes.

Limiting Damage	The installer is responsible for both internal and external protection of the property during the installation work. The existing windows and doorsets should be removed with care to avoid unnecessary damage to the building structure and its finishings, and without permitting any subsidence of the superstructure during or after the installation procedure. Care should be taken to avoid debris becoming embedded in soft garden areas (lawns, etc.). Care should be taken to avoid soiling of or damage to floor coverings and to decorations. Damage will inevitably be caused to the reveals adjacent to the installation, and it is essential that reasonable care be taken to keep this to a minimum. At the request of the installer, prior to the commencement of work, the purchaser should be given adequate notice to remove any furniture, fixings or fittings that might otherwise be damaged during the installation.
Weather-tightness	The installer should plan to install and seal the new windows and doorsets on the same day that the existing windows or doorsets are removed, to maintain security and the weather-tightness of the structure. When this is not practicable, for example on large contracts, an alternative arrangement for security and weather-tightness should be agreed in advance between installer and purchaser.
Special Requirements	Any electrical or specialist items, such as television aerials or telephone wires, should be routed around, and not through, the frame of the window or doorset. Where this is not feasible, then the routing should be carried out in accordance with the alternative solution agreed between the purchaser and the surveyor. This might require the services of the appropriate service provider.
Safety of Work	<p>Window and doorset removal and installation can be a dangerous operation. Safety precautions should be observed at all times. All new operatives should be trained in the safe use of all tools, and installation companies should ensure that their operatives have the correct equipment including personal protective equipment. Full training and assessment records of operatives should be kept. Important safety precautions include the following.</p> <ul style="list-style-type: none">• When handling glass, all operatives should wear eye protection, safety footwear and appropriate hand and wrist protection.• All electrically powered tools should either: work on 110 V mains power; or be battery operated (see BS 7671:2001, Section 604); or work on 240 V with a residual current detector of 30 mA maximum rating, especially where moisture is present.• A safe working platform to give safe access to the structural openings is essential.• When operating a grinding disc, the following safety precautions should be observed. Heavy gloves, face visors and helmets should be worn, clear access should be provided. Care should be taken that sparks cannot ignite combustible material such as dustsheets. All non-essential personnel should be moved a safe distance away.• Old windows and doorsets and other debris should always be stored and disposed of safely.

- Additional guidance on removing existing windows and doorsets is given in Annex B.

Installation – Aluminum windows and doors

Wherever practicable all four sides of the frame should be secured as follows. a) Corner jamb fixings should be between 100 mm and 150 mm from the external corner. b) No fixings should be less than 100 mm from the centre line of a mullion or transom. c) Intermediate fixings should be at centres no greater than 600 mm. d) There should be a minimum of two fixings on each jamb. e) On windows and doorsets over 1 800 mm wide, central head and sub-sill fixings should be provided.

Coupled assemblies

Coupled assemblies are usually delivered to site as separate units, to ease handling and minimize damage. When building up components into the required assembly, care should be taken to keep coupling joints equal, and frames both aligned and plumb. When coupling joints are also to be used as expansion joints, they should have seals, such as bedding mastic, expanding bituminized tapes, or flexible polymer gaskets, placed within the joint during the assembly operation. It is not sufficient to rely solely on external pointing sealant. Coupled assemblies should be fastened together in accordance with the manufacturer's instructions. Where the coupling is structural, the system supplier's recommendations should be followed.

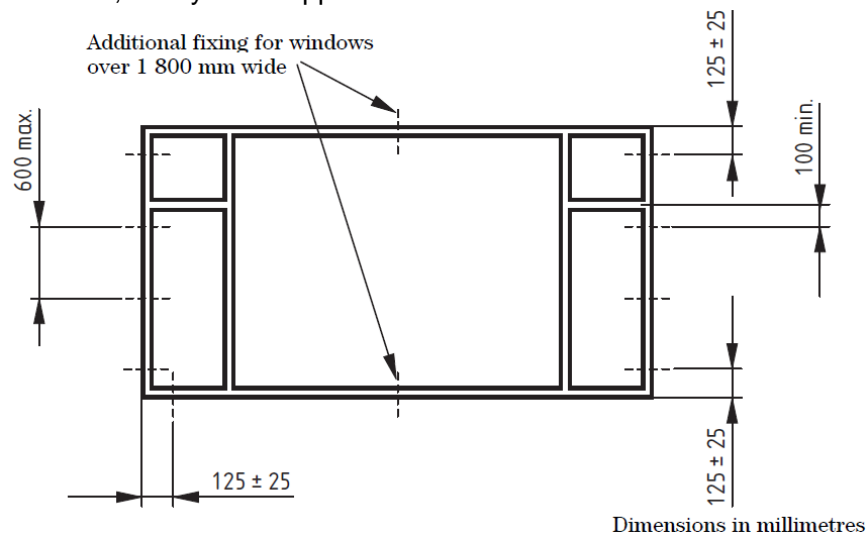

Installation

Windows and doorsets should be installed plumb and square within the aperture, without twist, racking or distortion of any member in accordance with the manufacturer's recommended tolerances, to operate correctly after installation and in accordance with the surveyor's instructions.

Frame Placement

Replacement windows and doorsets should generally be positioned to minimize the amount of making good, taking into account the following points.

- The new frame should bridge the DPM. Any damaged DPM should be repaired.
- The frame should be set as far back in the reveal as is feasible for better weather performance.
- The correct movement gap should be provided.

New Build the position of the window or doorset within the reveal is normally agreed at the time of original design and the installation should be in accordance with the agreed design.

Open Cavities

Open cavities discovered between inner and outer skins of brick or blockwork should be bridged or closed with an insulating material. Care should be taken to maintain the integrity of the DPM, and adequate purchase for fixing screws should be ensured, if need be with extended fixing lugs.

Installation packers

Installation packers should be used adjacent to fixing positions to prevent outer frame distortion during installation. Installation packers should be resistant to compression, rot and corrosion. They should span the full depth of the outer frame. The fixings should be tightened so that the frame is held securely against the packers. Over-

Finishing

tightening can lead to distortion and should be avoided. Some lugs need to be packed off the substrate to prevent distortion. Where enhanced security is required, additional packers might be necessary adjacent to hinge and locking points.

Debris or contaminants should be removed and any drainage paths should be cleared. Internal reveals should be made good as agreed, ready for the purchaser to redecorate if necessary. Any materials such as trims or sealant should not be applied on top of loose material. Protective tapes should be removed as soon as practicable, as ageing of tapes can cause difficulties in removal. Refer to the manufacturer's guidance. Sand and cement should not be used to fill the gap between the outer frame and the substrate except for backfill for steel windows, nowadays usually limited to windows in stone surrounds or interior fair-faced brick and concrete. Where the replacement product has a smaller front to back dimension than the original, then there might be a mastic and/or paint line visible on the substrate which should be removed as much as practicable or covered with a trim. The method of, and responsibility for, repair to any render should be as agreed with the purchaser.

Installation - Fixing

There are two principal methods of fixing available, which may be used separately or in combination: through frame fixings and lug fixings. The surveyor is responsible for specifying the nature, location and quantity of the fixings, taking into account the manufacturer's instructions. It is the responsibility of the installation company to ensure suitability, whether by recourse to third-party assessment or by some other means.

Imposed Loads	<p>For correct fixing, each frame member should be fixed to the substrate or to an adjacent window or doorset to resist all likely imposed loads that could cause the frame to deflect.</p> <ul style="list-style-type: none">• wind loads;• operating loads;• gravity;• accidental impact;• attempted burglary.
Fixing Considerations	<p>Fixing methods are affected by:</p> <ul style="list-style-type: none">• the presence or absence of a wall cavity;• the nature and condition of any cavity;• the relative position of the frame and cavity;• the position of the plaster line and the need to minimize disturbance and damage to interior decorations;• the design of the reveal;• any requirements for fire resistance.
Placement	<p>Wherever practicable the sides of the frame should be secured in accordance with the recommendations. If it is impossible to follow these recommendations, then, on large contracts, alternative positions should be agreed with the purchaser, and on domestic installations, the closest possible fixing positions should be used.</p>
Form Fixing	<p>The presence of pre-cast concrete or steel lintels can make it impracticable or pose severe difficulties in achieving the recommended fixing distances. In these instances the use of polyurethane foam has proved a useful adjunct to mechanical fixings, but foam fixings should under no circumstances be used as the sole method of fixing the entire frame into the reveal.</p>
Lug Fixing/Direct Fix	<p>A twist in such as ACVL130 lug anchor can provide can be installed into the outerframe then the lug connected to the sub structure. Screws should be sized to penetrate at least 25 mm into timber, plugged holes in brick, block, or masonry, unless equivalent demonstrable provision can be made by other means, e.g. in accordance with an appropriate structural code. Connections to steelwork up to 2 mm thick such as folded sheet lintels should be made with appropriate thread cutting screws. Connections to steelwork over 2 mm thick should be either into pre-tapped holes with machine screws of minimum 5 mm diameter, or with power-driven hardened self-drilling screws. Other proprietary mechanical fixing methods are available but will not necessarily be suitable for a given application. Fixings should be at least as corrosion-resistant as BS EN 1670:1998, Grade.</p>

Installation - Glazing

Windows and doorsets can be delivered ready glazed, alternatively they can be supplied with glass units and pre-formed glazing gaskets to be applied on site in accordance with the manufacturer's instructions. Some, systems in particular evolution, require glazing tapes. In all cases the manufacturer's instructions should be followed. All glazing should conform to the recommendations given in the relevant part of BS 6262. In addition, any glass or insulating glass unit manufacturer's instructions should be followed.

Inspection	All insulating glass units should be examined for damage prior to installation. Defective units should not be used.
Installation	Insulating glass units, setting and location blocks, distance pieces, frame to glass and bead to glass gaskets, bead to frame airseals, corner sealing blocks, beads and bead end caps, bedding and capping sealants should be installed in accordance with BS 8000-7
Setting Blocks Insulating/Safety Glass	Figure 5 shows the setting and location block positions recommended in BS 6262. Insulating glass units incorporating safety glass should be oriented with the safety glass on the appropriate side. It is a legal requirement that the marking on the safety glass remains visible after installation. Insulating glass units with low emissivity coatings should be oriented in accordance with the manufacturer's instructions. Failure to do so can render the coating less effective.

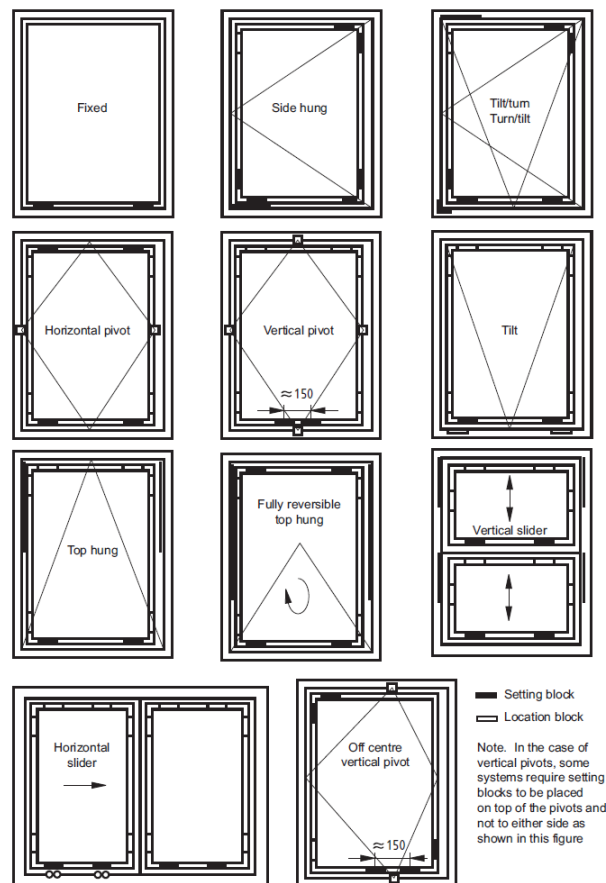

Installation - Sealing

The purpose of perimeter sealants is to repel water and prevent air leakage in the face of differential movement between the aperture and the window or doorset. Suitable sealants exhibit and retain flexibility and adhesion over this period. The movement class for the sealant will depend on the substrate material, the frame material and the dimensions of the joint between the frame and the opening.

Sealant Type Sealants should be tested and classified in accordance with BS EN ISO 11600. Unless an unusual and specific known requirement determines otherwise, they should be of low modulus and high elasticity, with movement capability of at least 20%. These characteristics should be identified on their packaging as class 20LM or 25LM.

Considerations Perimeter joints should be sealed, with a sealant appropriate to:

- the frame surface;
- the substrate material;
- joint size and configuration;
- anticipated joint movement;
- anticipated exposure to weather.

It is essential that sealants are compatible with the frame material and the substrate. The presence of old oil-based mastics and bituminous DPMs can adversely affect the behaviour or appearance of otherwise correctly specified and applied sealants, through the migration of hydrocarbons to the surface of the new sealants. Consequent photo-oxidation of the migrant products can affect sealant performance and produce discoloration. This risk should be avoided by removal of unwanted mastic and by keeping sealant away from DPMs. In situations where sealants rely upon atmospheric moisture to initiate curing, deep filling should be avoided.

Sealant Backing

The sealant should be applied against a firm backing so that it is forced against the sides of the joint during application. To avoid failure in service, the sealant should not adhere to the backing because this would restrict the lateral movement of the joint. These recommendations can be achieved through the use of a closed-cell, oversize circular foam strip. For aluminium framed windows and doorsets, recommended best practice is to have an insulating fill inserted or injected wherever practicable around their full perimeter behind the external seal between frame and structural opening.

Trims and pressings

All trims should be compatible with the material of the frame and should be colour matched where specified. Finishing trims, where used externally, should be good exterior quality materials used in accordance with the manufacturer's instructions. Cellular extruded PVC-UE trims should conform to BS 7619.

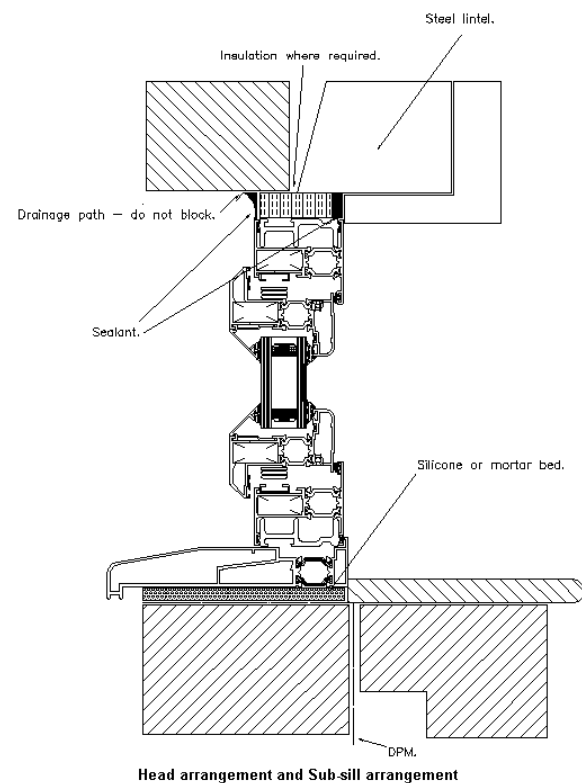

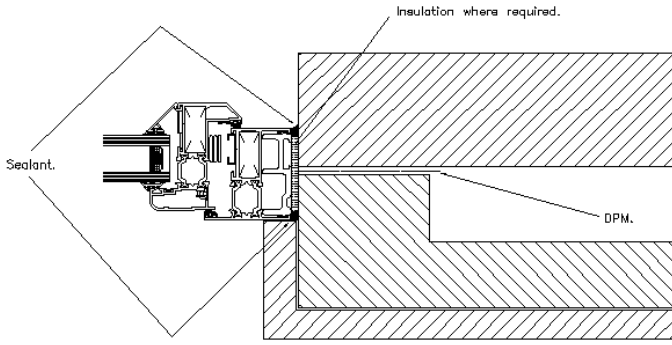

**Flush reveal frame bridging DPM
joint width less than 6 mm**

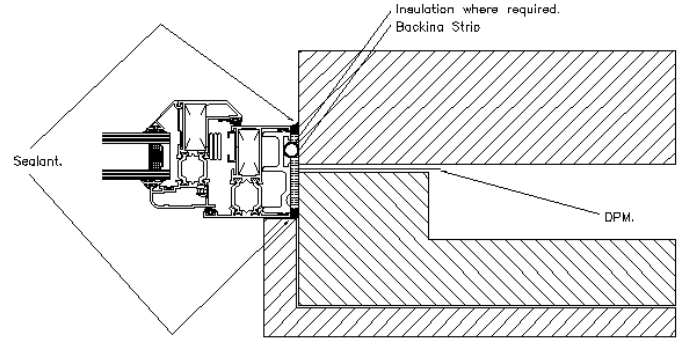

**Flush reveal frame bridging DPM
joint width from 6 mm to 15 mm**

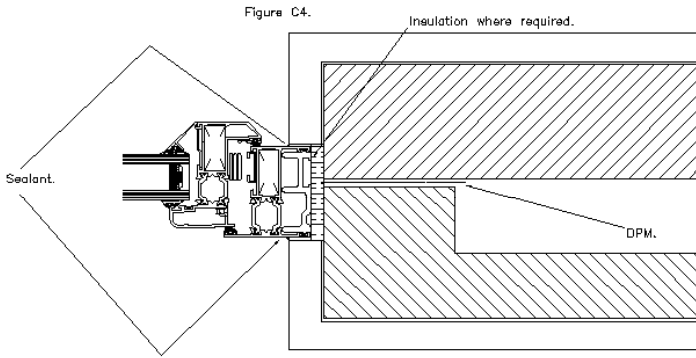

**Flush reveal with external render
for replacement windows/doorsets
with frame shuffled into position**

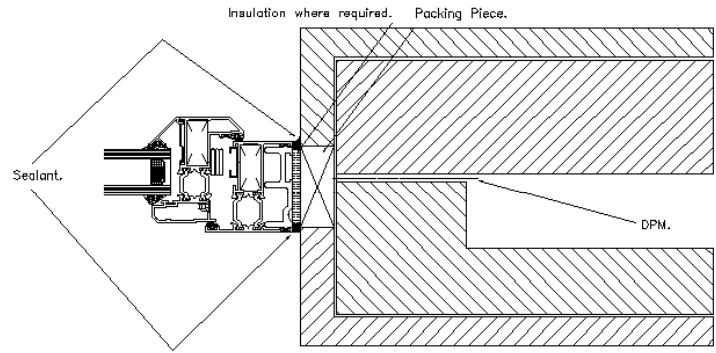

**Flush reveal with external render
for replacement frames**

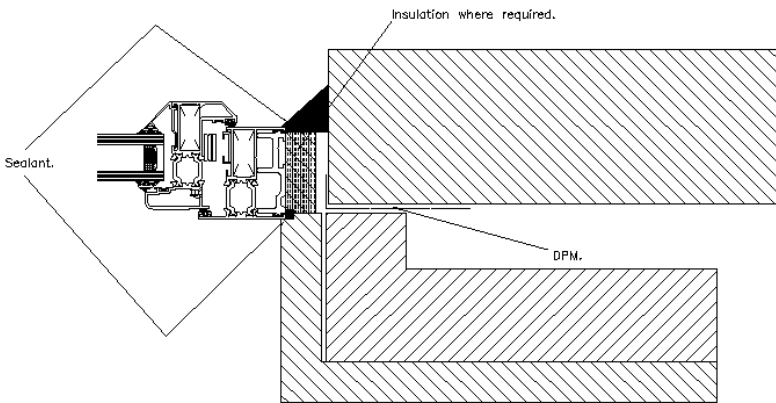

Frame forward of DPM

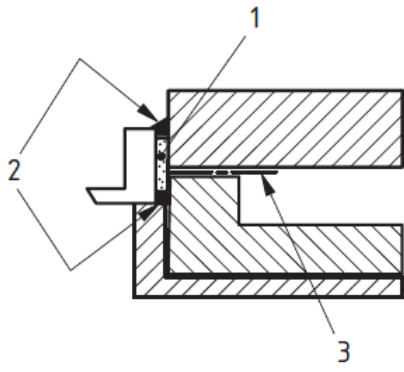

Key

- 1 Insulation where required (see 8.10)
- 2 Sealant
- 3 DPM

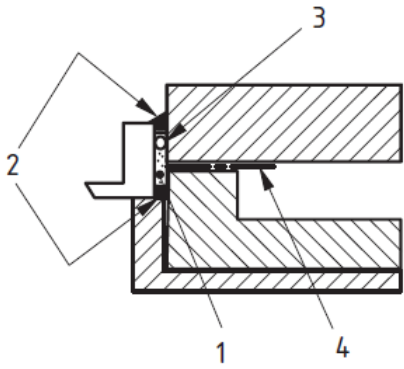

Key

- 1 Insulation where required (see 8.10)
- 2 Sealant
- 3 Backing strip
- 4 DPM

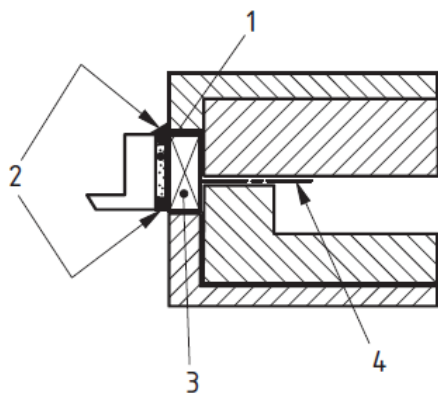

Key

- 1 Insulation where required (see 8.10)
- 2 Sealant
- 3 Packing piece
- 4 DPM

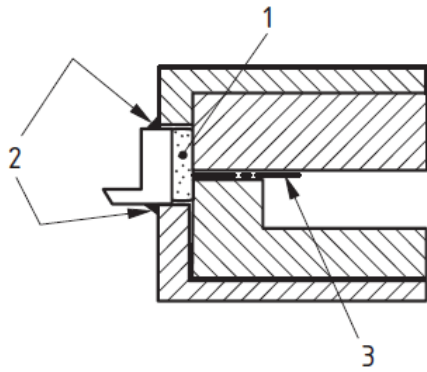

Key

- 1 Insulation where required (see 8.10)
- 2 Sealant
- 3 DPM

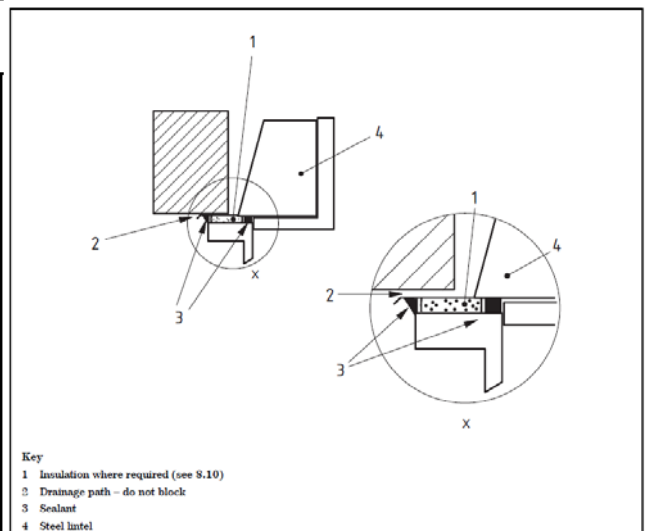
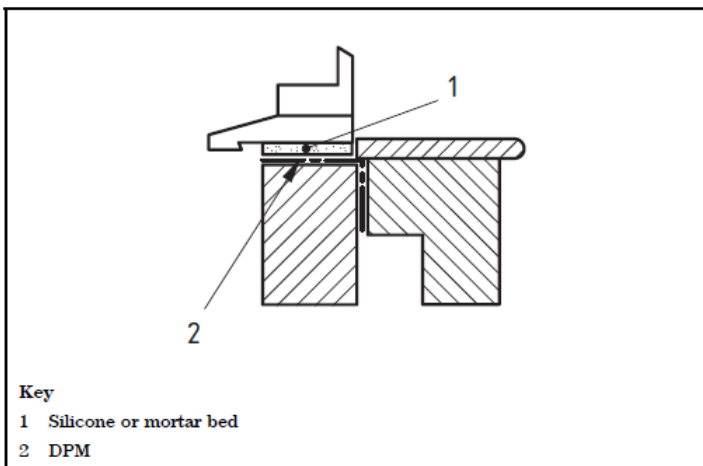
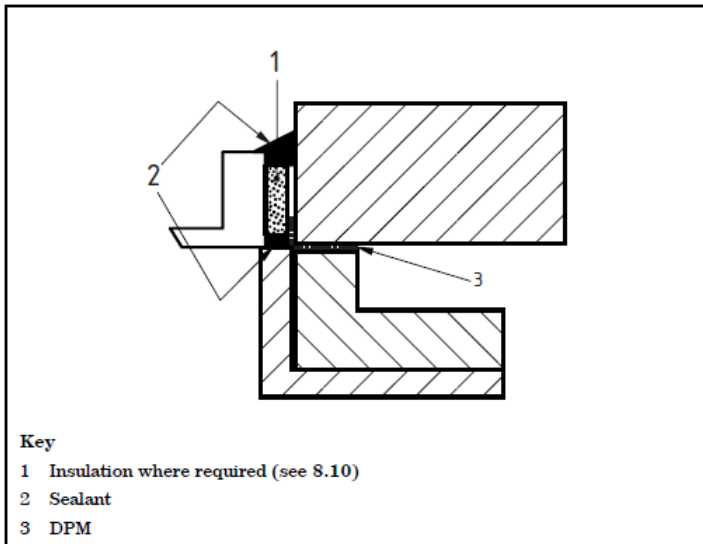
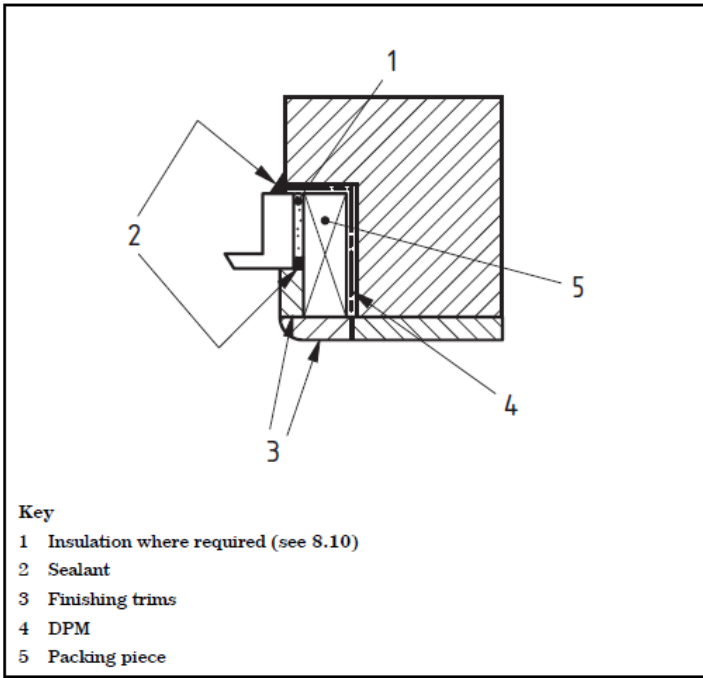

Installation - Commissioning

- Final Insepection After installation a final inspection should be carried out, preferably accompanied by the purchaser, to ensure that the installation is fully in accordance with the surveyor's and manufacturer's instructions. An example of a final checklist is given in **Annex A**.
- Correct Operation It is essential that the purchaser is made aware of the method(s) of operation, locking and unlocking and fire egress. This should be accompanied by written operating and maintenance instructions such as those published by trade federations. Ideally, all occupants of a household, other than small children, should carry out the operation of the windows and doorsets, particularly the operation of safety restrictors and their release for egress, in order to identify any difficulties any occupant might have and to agree remedies. Where it is not possible to pass the instructions directly to the occupant, e.g. in the case of housing association refurbishment, then it is the responsibility of the purchaser to ensure that the instructions are passed on. Information on the ordering of spare keys should be provided. In addition, it is good practice to have the purchaser or purchaser's designated representative sign off the installation after the inspection has been passed.

**CLEANING, MAINTENANCE AND REPAIR PROCEDURE FOR ORGANIC
PAINT COATINGS (ACRYLIC AND POLYESTER) ON ALUMINIUM AND PVC-U
WINDOWS, DOORS AND ARCHITECTURAL PRODUCTS**

INDEX

CLEANING AND MAINTENANCE

ALUMINIUM 4

PVC-U 5

REPAIR

ALUMINIUM 5

PVC-U 6

FABRICATION AND INSTALLATION 6

ORGANIC COATED ALUMINIUM 7

REPLACING DAMAGED COMPONENTS 8

WINDOW HARDWARE MAINTENANCE 8

DOOR HARDWARE MAINTENANCE 8

**DATE
12/08/08**

CLEANING, MAINTENANCE AND REPAIR

**PAGE
2**

**CLEANING, MAINTENANCE AND REPAIR PROCEDURE FOR ORGANIC
PAINT COATINGS (ACRYLIC AND POLYESTER) ON ALUMINIUM AND PVC-U
WINDOWS, DOORS AND ARCHITECTURAL PRODUCTS**

In compiling these guidelines we would also draw your attention to a publication by the Council for Aluminium in Building, 191 Cirencester Road, Charlton Kings, Cheltenham, Gloucestershire, GL53 8DF (Tel No: 01242 578278).

“Guidance in the handling, care, protection, fixing and maintenance of aluminium windows and doors.”

DATE
12/08/08

CLEANING, MAINTENANCE AND REPAIR

PAGE
3

**CLEANING, MAINTENANCE AND REPAIR PROCEDURE FOR ORGANIC
PAINT COATINGS (ACRYLIC AND POLYESTER) ON ALUMINIUM AND PVC-U
WINDOWS, DOORS AND ARCHITECTURAL PRODUCTS**

1. CLEANING AND MAINTENANCE

(ALUMINIUM)

- a) In areas within the direct influence zones of salt water, industrial chemical plants, blast furnaces or other aggressive emission sources, the window should be cleaned at least every three months. In a relatively cleaner environment every six months should be sufficient.

In carrying out regular maintenance outside, the internal surfaces are frequently neglected. After a period of time, grime and deposits from tobacco smoke, coal and oil fires, etc., can discolour the inside of the window frame and it is recommended that these should be cleaned at least once per year.

b) Procedure

- (i) Wash down with clean warm water containing a non-alkaline liquid detergent (in a concentration which can be handled safely with bare hands) using a non-abrasive cloth, sponge or soft bristle brush. This will remove grime, grease and any excess chalking. All ridges, grooves, joints and drainage channels where salt or other deposits can collect should be well washed out, thus preventing corrosion sites from occurring!
 - (ii) Rinse thoroughly with clean water.
 - (iii) Dry using a soft cloth or leather.
- c) Where a reduction in gloss is observed, chalking is evident or excessive staining has occurred, then an approved renovating cream may be carefully applied with a non-abrasive cloth.

Note: T-Cut or similar automotive paint restorer may be used provided it is not too abrasive!

Care must be taken not to abrade sharp corners of section or aris of beads too heavily where the paint film is normally thinner, and it should be remembered that this operation should not be carried out too frequently.

Polish with a soft cloth to restore gloss and colour uniformity.

DATE
12/08/08

CLEANING, MAINTENANCE AND REPAIR

PAGE
4

CLEANING, MAINTENANCE AND REPAIR PROCEDURE FOR ORGANIC PAINT COATINGS (ACRYLIC AND POLYESTER) ON ALUMINIUM AND PVC-U WINDOWS, DOORS AND ARCHITECTURAL PRODUCTS

- d) For extra protection a wax polish can be applied once or twice a year again polishing with a soft cloth to restore glass.

(PVC-U)

PVC-U profile, whether white self finish or woodgrain laminated, requires minimal maintenance. Occasional cleaning with soap and warm water is all that is normally required.

The laminated woodgrain effect finish is resistant to normal household agents, e.g. ammonia water, petrol, alcoholic drinks (<45% vol alcohol), non-abrasive cleaners and water. It is not resistant to organic solvents, paint thinners and removers which is also applicable to white self finish material.

2. REPAIR

(ALUMINIUM)

- a) Blisters and corrosion sites may originate from areas where mechanical damage or scratches have penetrated the paint coating through to the aluminium, or from cut bar or butt ends, mitres, drill holes or drainage slots, where the aluminium is unprotected (see part 3c).
- b) Procedure:
 - (i) Use fine grade 120-360 grit abrasive paper to remove corrosion products and any non-adherent paint.
 - (ii) Wipe with white spirit or approved cleaning solvents.
 - (iii) Ensure surface is absolutely dry before applying a thin priming coat. Allow 20-30 minutes to 'flash off' using a fine brush.
 - (iv) With a fine brush again, touch in the damaged and primed area with an air drying paint.

DATE 12/08/08	CLEANING, MAINTENANCE AND REPAIR	PAGE 5
-------------------------	---	------------------

CLEANING, MAINTENANCE AND REPAIR PROCEDURE FOR ORGANIC PAINT COATINGS (ACRYLIC AND POLYESTER) ON ALUMINIUM AND PVC-U WINDOWS, DOORS AND ARCHITECTURAL PRODUCTS

It should be recognized that the air drying paint will not possess the same weathering properties as the stoved organic coating, but nevertheless will give a reasonable amount of protection. Their use should of course be confined only to small areas of damage.

(PVC-U)

In the event of an incident causing damage to the surface area of the profile then:-

- a) For white self finish profile, use 400 grade fine paper. Jif or similar household cleaner can be used to remove small scratches and dents, working on the damaged area using a circular motion until indent is removed. Finish polish with Jif and sisal brush.
- b) For wood grain laminated finish use suitable touch-up paint to camouflage scratch.

3. AT THE FABRICATION AND INSTALLATION STAGE

- a) Grease marks, dirt and mastic spillage may be removed using white spirit or an approved solvent which will not soften the paint film or adversely affect its weathering properties.
- b) Self adhesive tapes and clear lacquers must not be applied as irreparable damage, under certain conditions, can occur to the organic coating.
- c) It is recommended that all cut bar ends, mitres and butt joints, drainage slots and drill holes should be coated with an air drying paint system including a primer/corrosion inhibitor and a top coat and/or suitable gap sealant to provide protection against the initiation of corrosion sites where the aluminium is exposed. This protection is particularly important if the units are to be fitted in coastal or other aggressive environments.
- d) Fabricators and installers should take maximum care during assembly, transit and fitting not to damage the paint coating.

Note: Beware swarf on benches, end damage of assembled frames in transit or on site and the careless use of sharp ended screwdrivers or other tools for forcing 'snap-fit' beads into position!

DATE 12/08/08	CLEANING, MAINTENANCE AND REPAIR	PAGE 6
-------------------------	---	------------------

CLEANING, MAINTENANCE AND REPAIR PROCEDURE FOR ORGANIC PAINT COATINGS (ACRYLIC AND POLYESTER) ON ALUMINIUM AND PVC-U WINDOWS, DOORS AND ARCHITECTURAL PRODUCTS

Note: Beware swarf on benches, end damage of assembled frames in transit or on site and the careless use of sharp ended screwdrivers or other tools for forcing 'snap-fit' beads into position!

If the paint film is unavoidably damaged and bare aluminium revealed, the damage must be repaired immediately using procedure 2b.

4. POINTS TO BEAR IN MIND WHEN SPECIFYING ORGANIC COATED ALUMINIUM

- a) No organic paint coating, whether polyester or acrylic (or indeed if the substrate if PVC-U) is 'maintenance free' and that especially when installing in coastal districts or areas with high industrial pollution, advice should be given at the time of installation regard the frequency and nature of cleaning maintenance needed.
- b) Modern organic finishes which we apply to architectural aluminium are practically identical to the types used on motor vehicles and therefore require a similar degree of care and attention which people typically lavish on their car bodywork.

The frequency of cleaning relates directly to the decorative standard which the householder wishes to maintain and also the particular environment where the units are situated.

- c) All paints 'chalk' to some extent in service and a reduction in gloss level will occur. The original finish can be easily restored using the procedure in 1c.

DATE 12/08/08	CLEANING, MAINTENANCE AND REPAIR	PAGE 7
-------------------------	---	------------------

**CLEANING, MAINTENANCE AND REPAIR PROCEDURE FOR ORGANIC
PAINT COATINGS (ACRYLIC AND POLYESTER) ON ALUMINIUM AND PVC-U
WINDOWS, DOORS AND ARCHITECTURAL PRODUCTS**

1. REPLACEMENT OF BROKEN GLASS

Windows and Doors can be re-glazed and the gaskets and weatherstripping replaced using the materials supplied.

Any damage to the gasket or beads may necessitate replacement to retain the weather performance of the product. (Refer to Supplier)

2. REPLACEMENT OF DAMAGED COMPONENTS

If damage occurs, the furniture and fittings can be readily replaced by releasing the fixing screws and changing the fitting. (Refer to Supplier)

3. WINDOW HARDWARE MAINTENANCE

The friction stays and locking mechanisms should be lubricated periodically to minimize wear and to ensure smooth operation.

Care should be taken to avoid applying lubricant to the friction pads as this will impair their braking action. The resistance of the pads can be adjusted, if necessary, with the brass screws provided in each pad.

4. DOOR HARDWARE MAINTENANCE

Hinges and locking mechanisms should be lubricated periodically to minimize wear and to ensure smooth operations.

DATE
12/08/08

CLEANING, MAINTENANCE AND REPAIR

PAGE
8

